

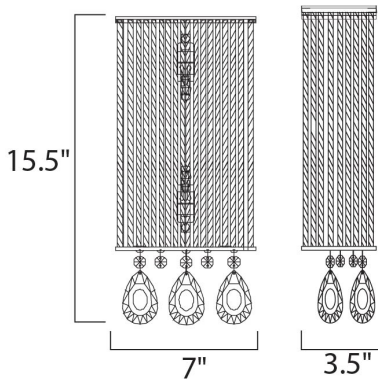

PRODUCT DESCRIPTION

Shades of textured glass rods supported in a Polished Chrome frame and draped with Clear beveled crystal form an elegant contemporary design. Powerful Xenon lamps included provide a warm and natural light.



MEASUREMENTS

DIMENSION : 7" W x 15.5" H x 3.5" Ext
 MAX OAH : 5.5" W x 11.42" H
 HANGING WEIGHT : 3.3 lb

LAMPING

INPUT VOLTAGE : 120V
 LUMENS : 1,000 Rated
 BULB : 2 x 40W Xenon G9 , 80W Total
 BULB INCLUDED : (Included)
 DIMMABLE : Yes

FINISHES OPTION

 Polished Chrome (PC)

GLASS

Clear 18

MATERIAL

Glass Rod, Steel

RATINGS

cETLus
 Dry Location
 ADA



ADDITIONAL

RATED LIFE 2000 Hours
 OPERATING TEMPERATURE:
 -20°C (-4°F), 40°C (104°F)

Always consult a qualified electrician before installing any lighting product.



Contemporary
 Lighting™

WESTERN DISTRIBUTION CENTER (HEADQUARTER)
 253 NORTH VINELAND AVE | CITY OF INDUSTRY, CA 91746

EASTERN DISTRIBUTION CENTER
 101 GARDNER PARK | PEACHTREE CITY, GA 30269

P. 626.956.4200 | F. 626.956.4225 | maxlighting.com